

TG

Series

Efficient Tube Fiber Laser Cutting Machine 1500W-12000W



- **Front chuck avoidance cutting**
Design for front chuck avoidance cutting,
resulting in minimal material waste and high pipe utilization rate
-

- **Pneumatic roller support**
Automatically adjusts according to the
diameter of the pipe, effectively supporting
the pipe to ensure cutting accuracy

- **Horizontal bed structure**
Horizontal bed design, with a strong lower
load-bearing capacity of the center of gravity,
ensuring stability during high-speed operation

Performance Advantages

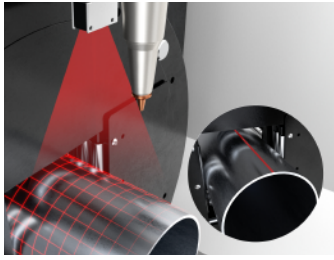

Weld Recognition

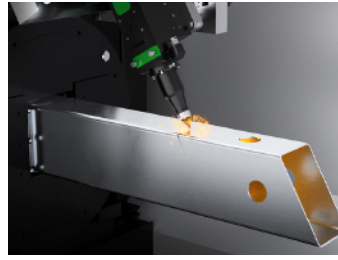

Bevel Cutting

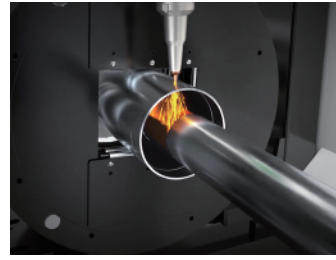

Internal Wall Protection

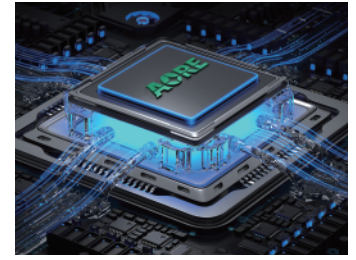

Intelligent Operating System

Technical Parameter

Model	TG6012	TG6016	TG6020	TG6035
Max. processing tube length	6300mm	6300mm	9300mm	12400mm
Laser power	1.5-3KW	1.5-3KW	1.5-6KW	3-12KW
Positioning accuracy	0.05mm			
Repeated positioning accuracy	0.03mm			
Max. running speed	130m/min	130m/min	110m/min	80m/min

Cutting Sample Display

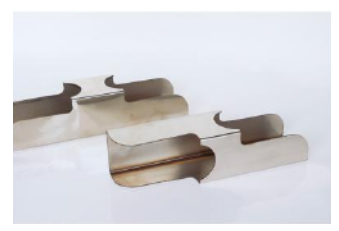

BLT 310T Cutting Head Technical Parameters



BOCI BLT310T เป็นหัวตัดไฟเบอร์เลเซอร์อัจฉริยะที่ออกแบบมาสำหรับงานตัดเลเซอร์กำลังต่ำถึงปานกลาง โดยรองรับกำลังเลเซอร์สูงสุด **≤4kW** โครงสร้างมีขนาดกะทัดรัด น้ำหนักเบา และติดตั้งง่าย เหมาะสำหรับเครื่องตัดท่อและงานตัดโลหะที่ต้องการความแม่นยำสูง พร้อมระบบเซนเซอร์อัจฉริยะภายในที่ช่วยตรวจสอบการทำงานแบบ **real-time** เพื่อเพิ่มความเสถียรและความปลอดภัยในการตัด



Cutting Head Parameters	Values
Laser Wavelength	1030 ~ 1090 nm
Laser Power	≤ 4 kW
Fiber Interface	QBH/EOC
Spot Magnification	M = 1.5/2.0/2.5 (100:150/100:200/100:250)
Max Focus Adjustment Range	±50 mm (±1.97 inches)
NA	Max.0.13 at Fc100
Centering Adjustment Range	±1.5 mm (±0.059 inches)
Focusing Acceleration	7.5 m/s ² (24.6 ft/s ²)
Cutting Gas Interface	∅10, max 25 bar (2.5 MPa)
Working Temperature	5 ~ 55°C (41 ~ 131°F)
Storage Temperature	-25 ~ +55°C (-13 ~ +131°F)
Dimension	405 x 119 mm (QBH version)
Weight	About 4.3 kg.(QBH version)

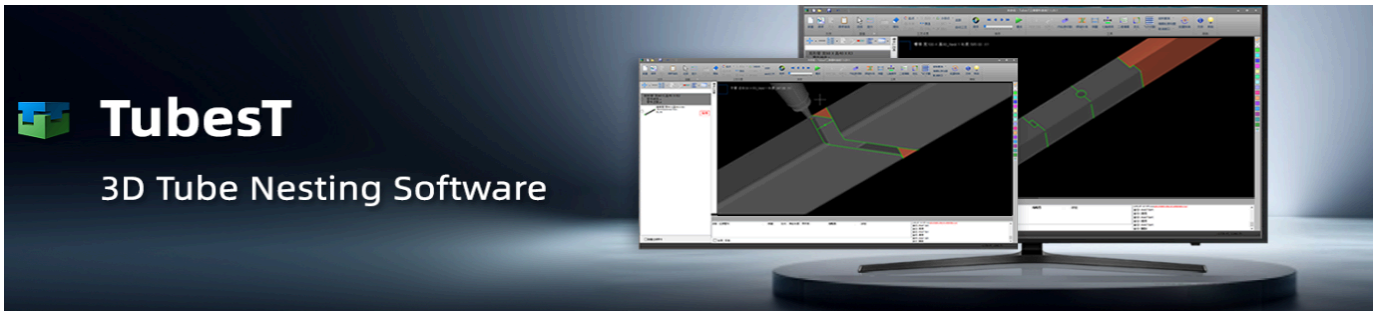

TubesT is a 3D tube nesting software designed for CypTube/TubePro laser cutting system. From parts drawing and modification, full type compensation, strategic nesting to report generation, using TubesT will meet and exceed your production needs.

Intelligent Nesting

TubesT supports nesting of parts of various shape all at once with minimum waste.

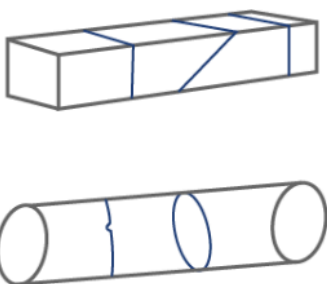
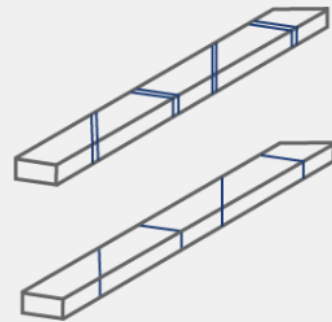

Flexible Common Line

Different parts, regardless of applied compensation, can merge common line toolpath in TubesT to reduce cutting times and minimize waste in production.

Quick Import

Parts or assemblies(IGS format) of multiple shapes can be imported in TubesT in a one-time operation to improve efficiency.



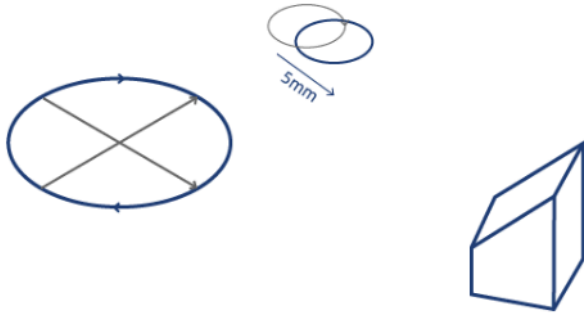

Drawing Modification

To solve the common problems in tube cutting, like through-hole precision and parts-assemble interference, TubesT developed flexible and easy-to-use functions for user to adjust parts drawing.

Automatic Sorting

Tube and profiles can finish automatic toolpath sorting by a simple click. For square and round tube, TubesT allows to generate toolpath by tube face sequence or by tube length interval.

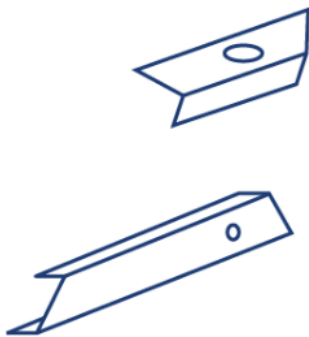
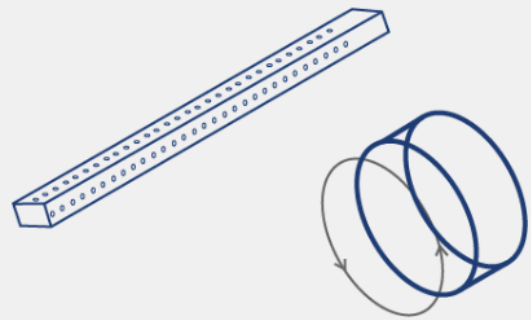

Profiles Production

TubesT supports toolpath generation, modification and common line nest of profiles like L/U/T/H shape to extend production ability of your machine.

Parts Design

TubesT integrates drawing functions of extrude, cut, hole and V-groove etc. , even user with zero CAD experience can get start easily.

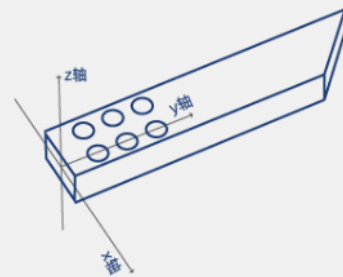

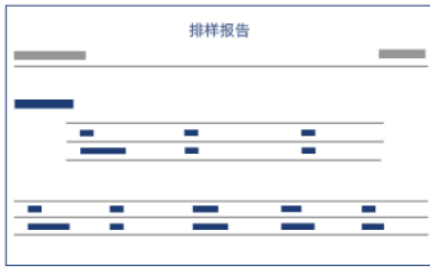

Nesting Report

Nesting report of clear data sheet to facilitate operator manage production schedule.



Auto Nest

Auto nest parts of different shape same time, also support to create common line toolpath in multiple patterns



Profiles and Free Forms

Support profiles of U/T/H/L shapes and free form shapes toolpath generation



Advanced Technique

Support advanced technique setting including Fly Cut, 2D editing and continuous toolpath generation



Assist Function

Support assembly file import, part drawing and nesting report functions



Function Comparison

Nesting Capability

Function	TubesT (optional)	TubesTLite (standard)
Array	✓	✓
Auto nest	✓	✗
Manual adjust nesting	✓	✗
Nest different parts on one tube	✓	✗
Nest parts of different shapes in one time	✓	✗
Generate common line toolpath of various patterns	✓	✗
Material-saving nest strategy	✓	✗
Tolerance-allowed nesting	✓	✗

Production Capability

Function	TubesT (optional)	TubesTLite (standard)
Circle/rectangle/Oround	✓	✓
Free form tube(close-contour section)	✓	✓
Profiles(L/T/H/U shapes)	✓	✗
Sharp corner rectangle	✓	✗
Other free form tube of complex shape	✓	✗

Production Technique

Function	TubesT (optional)	TubesTLite (standard)
Lead line, kerf width compensation, cooling point, micro-joint etc	✓	✓
Start point, reverse, inner/outer, gap, overcut etc	✓	✓
Weld kerf compensation	✓	✓
Through holes	✓	✓
Vertical/horizontal through holes	✓	✗
Create continuous toolpath	✓	✗
Extend compensation styles	✓	✗
Fly Cut	✓	✗
2D edit	✓	✗
Bevel cutting toolpath	✓	✗



Drawing Modification

Function	TubeST (optional)	TubeSTLite (standard)
Break, join line segment	✓	✓
Replace as point, flip, fine tune, R corner adjust	✓	✓
Draw wrapping	✓	✗
Text	✓	✗
Profile toolpath modification	✓	✗
Rotate tube section	✓	✗
Edit 3D vector of contour	✓	✗

Sorting

Function	TubeST (optional)	TubeSTLite (standard)
Sort along Y axis	✓	✓
Reverse sequence	✓	✗
Manual sort	✓	✗
Sort by tube face	✓	✗
Unfold 3D drawing to sort	✓	✗
Holes around cut-off section first	✓	✗
Optimize B axis rotation	✓	✗

File

Function	TubeST (optional)	TubeSTLite (standard)
Import IGS, SAT file	✓	✓
Import *.jhb file(TubeST generated)	✓	✗
Batch import part by Excel table	✓	✗
Import assembly part	✓	✗
Save/read YXY project file	✓	✗

Others

Function	TubeST (optional)	TubeSTLite (standard)
Measure	✓	✓
Simulation	✓	✓
Report	✓	✗

Fiber Lasers



Maxphotonics brings expertise to every fiber laser we engineer - ensuring performance, consistency, reliability, and cost-efficiency in even the most demanding environments.

Our solutions drive industrial success while optimizing your operational costs across a wide range of applications.

Maxphotonics ผู้นำด้านไฟเบอร์เลเซอร์ ที่ให้ทั้งพลัง ความแม่นยำ และความเสถียรในทุกการใช้งาน ออกแบบมาเพื่อรองรับงานอุตสาหกรรมหนัก พร้อมประสิทธิภาพที่สม่ำเสมอในทุกสภาพการทำงาน ช่วยเพิ่มกำลังการผลิต ลดต้นทุน และยกระดับคุณภาพงานตัดให้เหนือกว่า เทคโนโลยีที่เชื่อถือได้ พร้อมตอบโจทย์ทุกความต้องการของโรงงานยุคใหม่ เลือก Maxphotonics เพื่อประสิทธิภาพสูงสุดและความคุ้มค่าในระยะยาว

